

Cableway

Customer Needs:

Effectively manage the tangle of cables, cords and wires in an out-of-sight yet accessible "pocket."

User Requirements:

Manage cables and power at worksurface height for a clean aesthetic.

Product Features

- **Statement of Line:**

Style Number	Style Number*	Size	Weight
<i>(ships with Horizontal Mounting Brackets)</i>	<i>(ships with Universal Clamps)</i>		
AHORZ25	AC25	W25 x H8 x D3½	7.75 lbs.
AHORZ31	AC31	W31 x H8 x D3½	8.50 lbs.
AHORZ37	AC37	W37 x H8 x D3½	9.50 lbs.
AHORZ43	AC43	W43 x H8 x D3½	10.50 lbs.
AHORZ49	AC49	W49 x H8 x D3½	11.50 lbs.
AHORZ55	AC55	W55 x H8 x D3½	14.50 lbs.
AHORZ61	AC61	W61 x H8 x D3½	15.25 lbs.

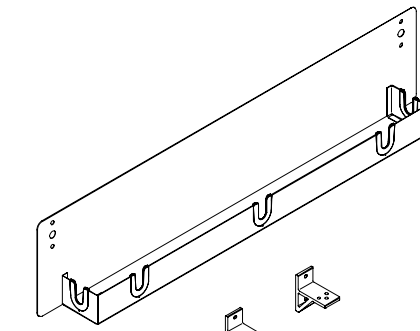

* Can be used in combination with Privacy and Modesty Screens (order appropriate assembly)

- Color: Black or Platinum
- Construction:
 - Cableway: Powder-coated sheet steel. Polypropylene grommets for smooth cable movement
 - Universal Clamp: Die cast aluminum with powder coat paint
 - Horizontal Mounting Bracket: Extruded aluminum with power coat paint
- Application: Mounts to a worksurface or tabletop
- Warranty: 10 years
- Positions top of Cableway ¼" above worksurface, this is a fixed height
- Gap between worksurface and Cableway is 1" to allow for cable feed through
- Clamps and Brackets are inset 2½" from both sides of the Cableway. When mounting a Cableway in combination with SlatRail Stanchions a SlatRail that is 1" shorter than the Cableway will **not** work due to the clamp locations
- Three clamps or brackets ship with 55" and 61" Cableways for additional support
- Cableways can be under worksurface mounted or c-clamped; ships with Horizontal Mounting Brackets or Universal Clamps (order appropriate assembly)
- Tool-free Universal Clamp clamps on worksurfaces 1" to 2" thick
- Universal Clamp uses a 2" footprint above and below the worksurface; Horizontal Bracket requires 2" of under worksurface clearance
- Rubber feet under Universal Clamp ensures a tight fit without marring worksurface
- Horizontal Bracket screws to underside of worksurface (installation required)

Call Details Customer Alliance for support - 800.833.0411

For a better day at work.™

details®

A STEELCASE COMPANY

P.O. Box 1967 / CD-5E / Grand Rapids, MI 49501-1967 / www.details-worktools.com

©2008 Office Details Inc. All Rights Reserved. Printed in U.S.A. 05/08
Subject to change without notice